

XII. *On the Resistance of Glass Globes and Cylinders to Collapse from external pressure; and on the Tensile and Compressive Strength of various kinds of Glass.*

By W. FAIRBAIRN, Esq., C.E., F.R.S., and THOMAS TATE, Esq.

Received May 3,—Read May 12, 1859.

THE recently published experiments upon the collapse of tubes of wrought iron*, led to results so novel and so much at variance with the ordinary rules of practice, as to exemplify anew the caution and diligence which are requisite in investigating the physical laws of nature, in order to arrive at just conclusions in regard to the properties of materials and their most effective distribution for the purposes of construction.

In the experiments alluded to, it was clearly shown that the prevailing ideas of the strength of vessels subjected to a uniform external force were erroneous and at variance with the laws of resistance to collapse under such circumstances; whilst in practice the prevalence of error in this matter had led to serious and sometimes fatal accidents, arising out of the construction of vessels of inadequate strength to sustain the pressures placed upon them. These errors, it is hoped, need no longer be perpetuated: the experiments on wrought iron indicated a means of increasing the strength of boiler flues and other vessels of that material, subjected to a collapsing force, to any required amount; and this was the immediate practical application of the general law then discovered, that the strength of cylindrical vessels, exposed to a uniform external force, varied inversely as the length between the rigid ends.

The results deduced from the experiments on tubes composed of riveted plates were so important as to suggest further inquiry, under the same conditions of rupture, but with other materials, differing in their physical properties from wrought iron. The joints in the tubes employed in those experiments were defects the influence of which might be determined by experiments upon homogeneous vessels. The ductile yielding character of wrought iron suggested the extension of the experiments to hard, rigid materials, more capable of retaining their form under pressure.

To fulfil the conditions thus sought for, *glass* was selected for experiment, as a material differing totally in character from wrought iron, and on that account well fitted to supply data for extending our knowledge of the laws of collapse. Of vitreous structure, rigid, elastic, and brittle, and of low tenacity, it possessed the further advantage of being easily obtained and blown into homogeneous vessels of the required forms. But there were other reasons which had weight in making this selection. Our acquaintance with

* Philosophical Transactions, 1858, pp. 389—413. Erratum in that paper: at page 408, in the place of "and by an obvious transformation," read "and when $k=0.43$, by an obvious transformation".

the strength of glass, in the various forms in which it is employed in the arts and in scientific research, is very limited; and often as it is employed in circumstances in which it is exposed to pressure, few attempts have been made to register observations of its strength. Some researches on the density of steam at high pressures, now in progress, led to an examination of the subject, and added, to other reasons for testing its powers of resistance, the immediate necessity of knowing more of its properties before it could be trusted in those experimental inquiries.

Our knowledge of the cohesive properties of glass is so defective, that, to arrive at satisfactory and complete results, it was deemed advisable to ascertain by direct experiment its tenacity, or resistance to a tensile strain, its resistance to a crushing force, and, in the form of globes and cylinders, to determine its resistance to an internal bursting force and to an external pressure tending to produce rupture by collapse. The results of the experiments upon glass globes and cylinders will, it is believed, form decided contributions to our present knowledge relative to the laws which determine the strength of materials. One remarkable result is that the law expressing the resistance of glass cylinders to compression is precisely similar to that which has been established for sheet-iron cylinders.

The glass experimented upon was of three kinds, known commercially as

Best Flint-glass,
Common Green Glass, and
Extra White Crown-glass.

The flint-glass obtained from Messrs. MOLINEAUX, WEBB, and Co., Manchester, was made of sand, oxide of lead, and carbonate of potash, in the following proportions:—

Sand	54 per cent.
Red oxide of lead	22 per cent.
Carbonate of potash	24 per cent.

This glass is of a fine transparent character, fusible, and of a high specific gravity, due to the large per-centage of lead in its composition.

The green and crown-glass were obtained from Messrs. CHANCE Brothers of Birmingham, and were made of sand, soda, and lime in the following proportions:—

Common Green Glass.

Sand	100 parts
Sulphate of soda	42 parts
Carbonate of lime	45 parts

This is a hard infusible glass of a green colour, transparent, but of a less density than the flint-glass.

White Crown-glass.

Sand	100 parts.
Carbonate of soda	38 parts.
Lime	11 parts.

A clear transparent glass, hard under the action of the grindstone, and highly infusible. The specific gravity of these different kinds of glass varies greatly; the following Table gives the result of several determinations:—

Specific Gravity of Glass.

Best flint-glass	3·0787	} Mean.	3·0782
Best flint-glass	3·0777		
Common green glass	2·5279	} 2·5284	
Common green glass	2·5289		
White crown-glass	2·4498	} 2·4504	
White crown-glass	2·4510		

SECTION I.—TENACITY OF GLASS.

A few experiments were made upon the tenacity of glass, by tearing specimens asunder by a direct tensile strain. These results, however, owing to the following circumstances, are not so satisfactory as could be wished. In breaking glass by the method adopted for other materials, namely, by suspending weights to it, there is danger that its great rigidity and brittleness may occasion its fracture before the entire cohesive force has been balanced by the strain applied, from the vibration of laying on the weights. In the experiments upon globes, however, in which a uniform water pressure was employed, the tenacity of the glass was ascertained with more accuracy, and any failure in the present experiments is therefore the less to be regretted. The glass to be broken by a tensile strain was obtained of the form shown in fig. 1, drawn smaller at the middle to secure fracture at that part. These specimens were fixed in a pair of wrought-iron shackles, and rested by their shoulders upon a thick india-rubber washer placed on the turned faces of the shackles. In this state they were suspended to a firm support, and a scale-pan attached to the lower shackle. Weights were then added, with the greatest care, till the specimen fractured. In this manner the following results were obtained:—

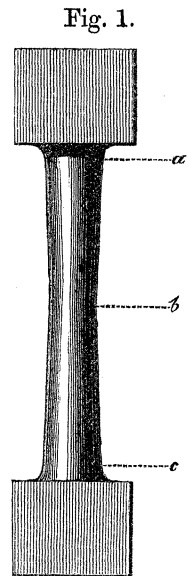

Experiment 1.

Annealed Flint-glass.

Least diameter	0·57 in.
Least area	0·255 sq. in.
Breaking weight, 583 lbs.=	2286 lbs. per square inch.

The fracture took place at *a*, fig. 1, and presented a regular smooth convex surface. No notch had been cut in this specimen.

Experiment 2.

Annealed Flint-glass.

Least diameter 0·50 in.
 Least area 0·196 sq. in.
 Breaking weight, 499 lbs.=2540 lbs. per square inch.

Broke in the notch at *b*, fig. 1, which in this case was cut by the grindstone. It is possible that the exterior coat of glass may be stronger than its core, in which case the above specimen was weakened. In the next experiments the specimens were drawn thinner by heat.

Experiment 3.

Common Green Glass.

Least diameter 0·53 in.
 Least area 0·220 sq. in.
 Breaking weight, 639 lbs.=2896 lbs. per square inch.

Experiment 4.

White Crown-glass.

Least diameter 0·54 in.
 Least area 0·229 sq. in.
 Breaking weight, 583 lbs.=2545 lbs. per square inch.

Broke at shoulder *a*, fig. 1.

The following Table exhibits at one view the results of these experiments, which, notwithstanding the objections to the method by which they were obtained, appear to be consistent with each other.

TABLE I.—Tensile Strength of Glass Bars.

Description of glass.	Area of specimen, in inches.	Breaking weight, in lbs.	Tenacity per square inch,	
			in lbs.	in tons.
Flint-glass	0·255	583	2286	1·02
	0·196	499	2540	1·13
Green glass	0·220	639	2896	1·29
Crown-glass	0·229	583	2546	1·14

It may be observed here, in anticipation, that the tensile strength is much smaller in the case of glass fractured by a direct strain in the form of bars, than when burst by internal pressure in the form of thin globes. This difference is no doubt mainly due to the fact that thin plates of this material generally possess a higher tenacity than stout bars, which, under the most favourable circumstances, may be but imperfectly

annealed. There is also a considerable discrepancy between the strength of green and crown-glass when in the form of bars and when in the form of globes. In the case of the bars, the results are as 1.0 to 1.13 in favour of green glass, whilst in the case of the globes, the results are as 1.0 to 1.2 in favour of the crown-glass. These discrepancies may, however, be accounted for from the different condition of the material in relation to annealing in the two cases, or from an imperfect bedding of the specimen, causing a distortion of the strain out of the direction of the axis of the specimen, or from accidental vibration in laying on the weights.

SECTION II.—RESISTANCE OF GLASS TO CRUSHING.

The next series of experiments was instituted with a view of determining the powers

Fig. 3.

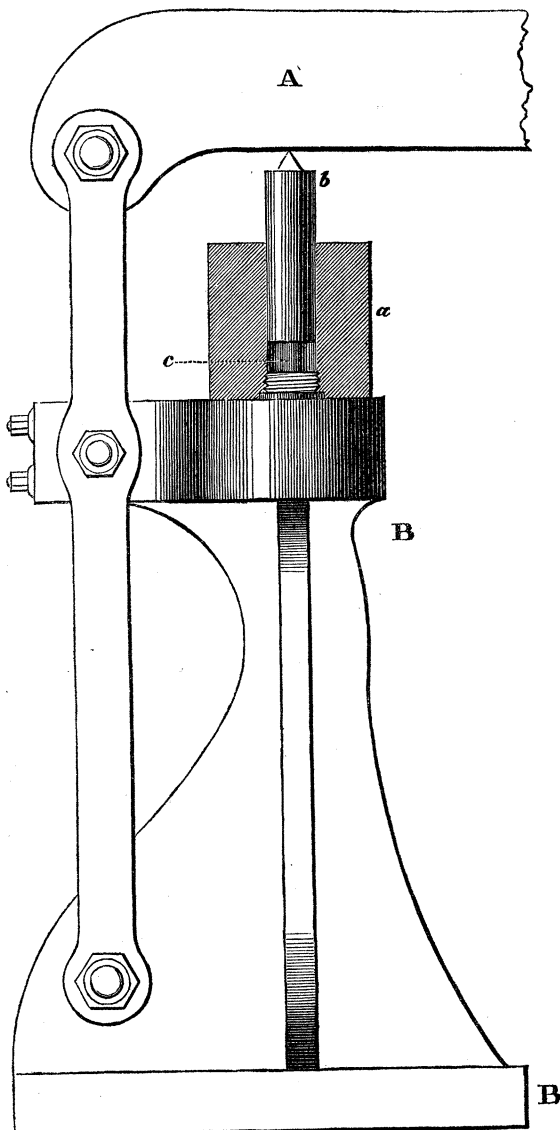

Scale. 2 ins = 1 Ft.

Fig. 2.

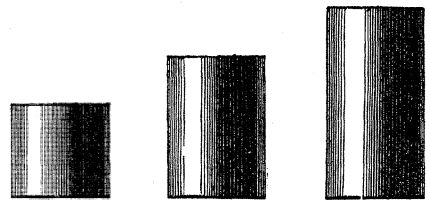

of resistance of glass to a direct crushing force. The specimens subjected to experiment were small cylinders (fig. 2) varying in length from 1 to 2 inches, and about three-quarters of an inch in diameter. They were placed for the purpose of crushing within the box *a* (fig. 3), thin packings of soft lead being interposed between the glass and the parallel crushing surfaces of the box and its solid steel piston *b*; in this way a firm and uniform bearing surface was secured, and the crushing force was applied perpendicularly in the direction of the axis of the specimen. Fig. 3 exhibits the general arrangement of the crushing apparatus, consisting of a lever *A*, 8 feet long, supported on a strong cast-iron base *B*, *B*. The crushing force obtained by placing weights in the scale-pan hung at the extremity of the lever is transmitted through the piston *b*, to the specimen to be crushed, *c*.

Flint-glass Cylinders.

Experiment 1.

Diameter 0·85 inch.
 Area 0·5674 square inch
 Height 1·0 inch.
 Placed between india-rubber packings.

This specimen having been slightly fractured at an early stage in the experiment, it was taken out and the fractured side ground flat preparatory to another trial.

Experiment 2.

The same specimen as in Experiment 1.

Diameter 0·85 inch.
 Height of segment (*ab*) 0·73 inch.
 Area 0·555 inch.
 Height of specimen 1·0 inch.

Fig. 4.

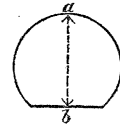

Weights added, in lbs.	Total weight, in lbs.		Weights added, in lbs.	Total weight, in lbs.	
1321	1321		224	10569	
2080	3401		224	10793	
896	4297		224	11017	
896	5193		224	11241	
896	6089		224	11465	
896	6985		224	11689	
896	7881		224	11913	
448	8329		224	12137	
448	8777		224	12361	
448	9225	Fractured	224	12585	
224	9449		112	12697	
224	9673		112	12809	
224	9897		112	12921	
224	10121		112	13033	Crushed
224	10345				

Fractured with 9,225 lbs.=16,621 lbs. per square inch.

Crushed with 13,033 lbs.=23,483 lbs. per square inch.

It will not be necessary again to repeat in detail the steps by which the weights were augmented, as these were similar in every case. In the succeeding experiments the weights at which the specimens fractured and crushed are alone given.

Experiment 3.

Diameter 0·69 inch.
 Area 0·3739 square inch.
 Height 1·0 inch.
 Fractured with 11,465 lbs.=30,661 lbs. per square inch.
 Crushed with 13,033 lbs. =34,854 lbs. per square inch.

Experiment 4*.

Diameter 0·70 inch.
 Area 0·3848 square inch.
 Height 1·55 inch.
 Crushed suddenly with 5193 lbs.=13,494 lbs. per square inch.

Experiment 5.

Diameter 0·83 inch.
 Area 0·541 square inch.
 Height 1·6 inch.
 Crushed suddenly with 11,241 lbs.=20,775 lbs. per square inch.

Experiment 6.

Diameter 0·68 inch.
 Area 0·3631 square inch.
 Height 2·05 inches.
 Crushed with 11,913 lbs.=32,803 lbs. per square inch.

Green Glass Cylinders.

Experiment 7.

Diameter 0·77 inch.
 Area 0·466 square inch.
 Height 1·0 inch.
 Fractured with 6933 lbs.=14,888 lbs. per square inch.
 Crushed with 10,516 lbs.=22,583 lbs. per square inch.

Experiment 8.

Diameter 0·76 inch.
 Area 0·454 square inch.
 Height 1·5 inch.
 Fractured with 8126 lbs.=17,883 lbs. per square inch.
 Crushed with 15,891 lbs.=35,029 lbs. per square inch.

* This experiment is so evidently anomalous, that there can be little doubt that the bedding surfaces were not parallel; hence this result is omitted in the following averages.

Experiment 9.

Diameter 0·79 inch.
 Area 0·4901 square inch.
 Height 2·0 inches.

Sustained a weight of 18,634 lbs.=38,015 lbs. per square inch, without being crushed. At this point the deflection of the lever was so great, that it was considered dangerous to proceed. On removing the specimen to a heavier lever, it crushed with a force of 12,000 lbs. The larger weight, however, had been fairly supported.

Crown-glass Cylinders.

The two cylinders of crown-glass were slightly rounded towards the edge of the bearing surfaces, which reduced the area directly subjected to the crushing force. It is therefore probably most accurate to take the less area in reducing the results.

Experiment 10.

Diameter { 0·72 inch at middle.
 0·68 inch at ends.
 Area 0·363 square inch.
 Height 1·5 inch.
 Crushed suddenly with 14,100 lbs.=38,825 lbs. per square inch.

Experiment 11.

Diameter { 0·80 inch at middle.
 0·76 inch at ends.
 Area 0·454 square inch.
 Height 1·0 inch.
 Crushed suddenly with 10,516 lbs.=23,181 lbs. per square inch.

Arranging the above results together, we obtain the following general Table of the results of the experiments:—

TABLE II.—Summary of Results of Experiments on the Resistance of Annealed Glass Cylinders to Crushing.

Description of glass.	Height of cylinder, in inches.	Area of cylinder, in inches.	Weight causing fracture, in lbs.	Crushing weight, in lbs.	Weight per sq. in. to cause fracture. lbs.	Weight per sq. in. to crush. lbs.
Flint-glass	1·00	0·555	9,225	13,033	16,621	23,483
	1·00	0·374	11,465	13,033	30,661	34,854
	1·60	0·541	11,241	20,775
	2·05	0·363	11,913	32,803
Green glass	1·00	0·466	6,933	10,516	14,888	22,583
	1·50	0·454	8,126	15,891	17,883	35,029
	2·00	0·490	18,634	38,015
Crown-glass.....	1·0	0·454	10,516	23,181
	1·5	0·363	14,100	38,825

Taking the means of the above values, and reducing the weights to tons, we have—

TABLE III.—Mean Compressive Resistance of Glass.

Description of glass.	Height of cylinder, in inches.	Crushing weight per square inch,		Mean crushing weight per square inch,	
		in lbs.	in tons.	in lbs.	in tons.
Flint-glass	1.0	29,168	13.021	} 27,582	12.313
	1.6	20,775	9.274		
	2.0	32,803	14.644		
Green glass.....	1.0	22,583	10.081	} 31,876	14.227
	1.5	35,029	15.628		
	2.0	38,015	16.971		
Crown-glass	1.0	23,181	10.348	} 31,003	13.840
	1.5	38,825	17.332		

The mean resistance of glass to a crushing force is therefore, from the above experiments, equivalent to 13.460 tons per square inch. Assuming the above numbers to represent the comparative values of each kind of glass, and taking flint-glass as the standard, we have their respective strengths as follow :—

- Green glass 1152
- Crown-glass 1124
- Flint-glass 1000

The specimens were crushed almost to powder from the violence of the concussion, when they gave way; it however appeared that the fractures occurred in vertical planes, splitting up the specimen in all directions. This characteristic mode of disintegration has been noticed before, especially with vitrified brick and indurated limestone. The experiments following on cubes of glass which were exposed to view during the crushing process, illustrated this subject further: cracks were noticed to form some time before the specimen finally gave way; then these rapidly increased in number, splitting the glass into innumerable irregular prisms of the same height as the cube; finally these bent or broke, and the pressure, no longer bedded on a firm surface, destroyed the specimen. The annexed ideal sketch (fig. 5) may give some notion of the fractures of a cube, supposing all the particles were restored to their position after crushing.

Fig. 5.

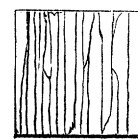

The specimens employed in the following experiments were cut from the square heads of the pieces of glass employed in the experiments on tensile strain (fig. 1). These pieces were approximately cubical; and their size prevented their insertion in the box *a* (fig. 3); they were therefore crushed between parallel steel discs, exposed to view. The crushing was more gradual, and was not effected so completely in these experiments as in those on small cylinders, the fragments being in every case larger after the conclusion of the experiment: it must further be recollected, in comparing these with the preceding experiments, that the cylinders were cut off, of the required length, from rods of glass drawn out when molten to the diameter desired, so

as to retain the first-cooled exterior skin of glass, which is probably of greater tenacity than the interior; on the other hand, the cubes were cut from the centre of larger lumps of glass, and were possibly in a state of imperfect annealing.

Flint-glass Cubes.

Experiment 12.

Area = 0.96×0.97 inch = 0.9312 square inch.

Height = 1.15 inch.

Crushed suddenly with 13,257 lbs. = 14,235 lbs. per square inch.

Experiment 13.

Area = 0.99×0.98 inch = 0.9702 square inch.

Height = 1.16 inch.

Crushed with 12,809 lbs. = 13,202 lbs. per square inch.

Experiment 14.

Area = 0.98×1.02 inch = 0.9996 square inch.

Height = 1.10 inch.

Crushed with 13,257 lbs. = 13,262 lbs. per square inch.

Experiment 15.

Area = 0.98 inch \times 0.98 in. = 0.9604 square inch.

Height = 1.10 inch.

Fractured with 6537 lbs. = 6806 lbs. per square inch.

Crushed with 11,353 lbs. = 11,820 lbs. per square inch.

Green Glass Cubes.

Experiment 16.

Area = 1.0×0.98 inch = 0.98 square inch.

Height = 1.0 inch.

Crushed with 20,059 lbs. = 20,468 lbs. per square inch.

Experiment 17.

Area = 0.99×1.2 inch = 1.188 square inch.

Height = 1.0 inch.

Crushed with 23,535 lbs. = 19,945 lbs. per square inch.

Crown-glass Cube.

Experiment 18.

Area = 0.82×0.92 inch = 0.7534 square inch.

Height = 0.9 inch.

Crushed with $16,475$ lbs. = $21,867$ lbs. per square inch.

This crushed suddenly after bearing the weight some time, and was reduced almost to powder.

TABLE IV.—Summary of the Results of Experiments on the Resistance of Cut Glass Cubes to Compression.

Description of glass.	Area of specimen, in square inch.	Crushing weight, in lbs.	Resistance to crushing per square inch,	
			in lbs.	in tons.
Flint-glass	0.9312	13,257	14,235	6.355
	0.9702	12,809	13,202	5.894
	0.9996	13,257	13,262	5.921
	0.9604	11,353	11,820	5.276
Green glass.....	0.9800	20,059	20,468	9.116
	1.1880	23,535	19,945	8.904
Crown-glass	0.7534	16,475	21,867	9.762

Hence the mean resistance to crushing of cubes of glass is equivalent to a weight of—

	lbs.
For flint-glass	13,130
For green glass	20,206
For crown-glass	21,867
Mean	18,401

Comparing these with the preceding results on glass cylinders, we have the mean resistance of the former experiments to the mean resistance of the above as $30,153:18,401$, or as $1.6:1$.

General Observations relative to the Results of the Experiments on the Resistance of Glass Cylinders and Cubes to Crushing.

With iron and some other materials, when a short column undergoes a pressure in the direction of its length, rupture takes place in a plane having a determinate angle to the axis of the column, this plane being the section of least resistance. Neglecting the friction of the surfaces, COULOMB found this angle to be 45° ; and allowing on an average 10° for the limiting angle of friction, the angle of the plane of rupture may be taken at 55° . To fulfil this condition, the length of the column to be crushed should be at least three times its radius: when the length greatly exceeds this limit, the rupture will be effected by the tendency of the column to bend; and when the length is within this limit,

the force requisite to produce rupture will be increased in consequence of the irregular form of the line of fracture. These theoretical deductions have been confirmed by experiments made upon columns of iron, wood, bone, stone, and other materials. The results of the experiments here recorded, however, show that when the length of the cylinder does not greatly differ from three times its radius, the resistance to a crushing force is pretty nearly a constant, viz. on an average 12·313 tons per square inch in the case of flint-glass, 14·227 tons in the case of green glass, and 13·84 tons in the case of crown-glass. But, according to COULOMB'S law, the cubes of flint-glass (their lengths being considerably less than three times their semi-diameters) should have presented higher powers of resistance than the cylinders; this discrepancy is probably owing to the injury which the glass had sustained in the process of cutting, and to the imperfect annealing of glass when cast in the form of cubes and cylinders.

SECTION III.—RESISTANCE OF GLASS GLOBES AND CYLINDERS TO INTERNAL PRESSURE.

In the following experiments it has been sought not only to determine the law of resistance to internal pressure, which is already well known from theoretical considerations, but to ascertain the direct tensile strength of the glass (of which the bursting pressure is a function) by a method free from many of the objections to that described in Section I. The bursting pressure of cylindrical and spherical vessels is well known to be in the ratio of the tenacity of the material, other things being the same, and the determination of the tensile strength upon this principle, presents in the case of glass peculiar advantages. As glass can be obtained in tolerably perfect spheres, and as the fracture of these may be effected by a uniform water pressure, increasing slowly and regularly without vibration, there is a better chance of ascertaining the ultimate resistance of the material, from the absence of those shocks and irregularities which are inseparable from any process depending upon the piling up of weights, however carefully conducted.

In making these experiments, a number of glass globes were procured of varying size and thickness. The stems were then flanged out by the blowpipe (fig. 6), and the diameter having been carefully measured, they were ready for experiment. To effect their rupture, each globe, *k* (fig. 7), was attached by means of a stuffing-box (*a*) to the cover of a strong wrought-iron boiler *B*, and was enclosed by the iron cylindrical vessel *d*, to prevent the dispersion of the fragments when rupture took place. In the stuffing-box the flanch of the stem of the globe was bedded upon vulcanized india-rubber, in such a manner as to secure a water-tight attachment without impeding the access of the water to the interior of the globe. The boiler was connected with a hydraulic pump by means of the pipe *b*, and an accurate gauge of the Schaeffer construction was fixed to the boiler to register the pressure. With this arrangement it will be seen that as the pumping was continued the water

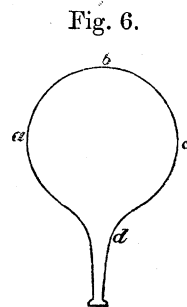

would rise in the globe, compressing the air in its interior, progressively, up to the point at which the resistance of the glass was overcome by the expansive force of the fluid; at that point explosion would take place, the pressure in pounds per square inch being noted both by the eye of the observer and by the maximum finger of the gauge.

Fig. 7.

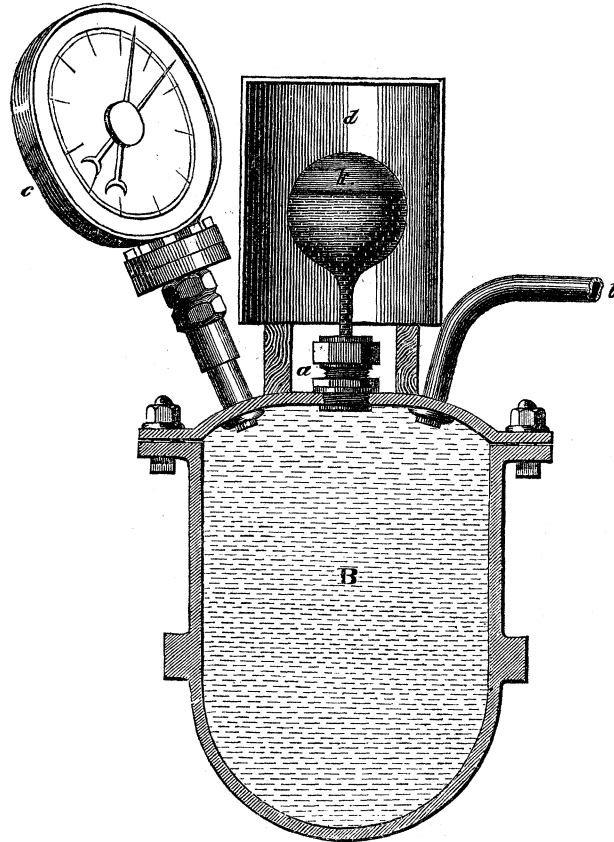

In glass globes generally, the upper half of the sphere *a*, *b*, *c* (fig. 6) is the most spherical, and is approximately uniform in thickness, being however thinnest at *b*, and thickening gradually downwards towards the stem, the lower half (*a*, *d*, *c*) being considerably the strongest. Hence it happened, in several cases (in fact in every case in which the point could be determined with certainty from the condition of the fragments), that the globes ruptured first at *b*, the lines of fracture radiating in every direction, passing round the globe as meridians of longitude, and splitting it up into thin bands, varying from $\frac{1}{20}$ th to $\frac{1}{8}$ th inch in width. In the case of some elongated ellipsoids, it appeared that the fractures occurred horizontally, or perhaps obliquely, from the condition of the fragments attached to the stem. In most cases, however, it was not clear from the fragments which had been the direction of the fracture, although the mode of rupture was the same in every case.

To ascertain the thickness, several specimens were selected from the thinnest fragments, and each being measured separately by a micrometer screw of fifty threads to

the inch and reading on a graduated head to $\frac{1}{5000}$ th of an inch, the minimum thickness was assumed as that of the part which ruptured, and has been employed in reducing the results.

It must also be observed that the globes were usually slightly elliptical, in some cases seriously so; the vertical diameter, $b d$ (using the same form of expression as before), being generally less than the horizontal, $a c$. In the following Tables the two diameters are given in each case.

Flint-glass.

Experiment 1.

Globe a. Diameters 4.0 and 3.98 inches.

In parts of an inch.

$$\text{Thicknesses measured } \left\{ \begin{array}{l} 0.0230 \\ 0.0256 \\ 0.0284 \\ 0.0244 \\ 0.0302 \\ 0.0250 \\ 0.0240 \end{array} \right\} \text{ Minimum} = 0.024 \text{ inch.}$$

Bursting pressure = 84 lbs. per square inch.

Experiment 2.

Globe b. Diameters 4.0 and 3.98 inches.

In parts of an inch.

$$\text{Thicknesses measured } \left\{ \begin{array}{l} 0.034 \\ 0.032 \\ 0.031 \\ 0.0254 \\ 0.0256 \\ 0.031 \\ 0.028 \end{array} \right\} \text{ Minimum} = 0.025 \text{ inch.}$$

Bursting pressure = 93 lbs. per square inch.

Experiment 3.

Globe c. Diameter 4.0 inches.

In parts of an inch.

$$\text{Thicknesses measured } \left\{ \begin{array}{l} 0.040 \\ 0.0406 \\ 0.039 \\ 0.039 \\ 0.038 \end{array} \right\} \text{ Minimum} = 0.038 \text{ inch.}$$

Bursting pressure = 150 lbs. per square inch.

Experiment 4.

Globe d. Diameters 4.5 and 4.55 inches.

In parts of an inch.

Thicknesses measured	}	0.0620	} Minimum = 0.056 inch.
		0.0694	
		0.0584	
		0.0626	
		0.0564	
		0.0614	
		0.0604	
		0.0580	

Burst with 280 lbs. per square inch.

Experiment 5.

Globe e. Diameters 5.1 and 5.12 inches.

In parts of an inch.

Thicknesses measured	}	0.0580	} Minimum = 0.058 inch.
		0.059	
		0.0586	
		0.0634	
		0.0620	
		0.059	

Burst with 184 lbs. per square inch.

Experiment 6.

Globe f. Diameter 6.0 inches.

In parts of an inch.

Thicknesses measured	}	0.060	} Minimum = 0.059 inch.
		0.066	
		0.060	
		0.059	
		0.0592	
		0.0592	

Burst with 152 lbs. per square inch.

Experiment 7.

Cylinder g. Diameter 4.05 inches. Length 7.0 inches.

In parts of an inch.

Thicknesses measured	}	0.079	} Minimum = 0.079 inch.
		0.081	
		0.090	
		0.086	
		0.086	
		0.079	
		0.086	

Burst with 282 lbs. per square inch.

Fig. 8.

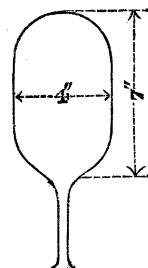

Green Glass.

Experiment 8.

Globe k. Diameters 4.95 and 5.0 inches.

In parts of an inch.

Thicknesses measured	0.029	} Minimum = 0.022 inch.
	0.024	
	0.026	
	0.022	
	0.025	
	0.023	
	0.024	
	0.0225	

Bursting pressure = 90 lbs. per square inch.

Experiment 9.

Globe l. Diameters 4.95 and 5.0 inches.

In parts of an inch.

Thicknesses measured	0.024	} Minimum = 0.020 inch.
	0.023	
	0.022	
	0.0196	
	0.023	
	0.022	
	0.020	
	0.020	

Burst with 85 lbs. per square inch.

Experiment 10.

Globe m. Diameters 4.0 and 4.05 inches.

In parts of an inch.

Thicknesses measured	0.020	} Minimum = 0.018 inch.
	0.0205	
	0.0202	
	0.021	
	0.018	
	0.020	
	0.023	
	0.0205	
	0.0215	
	0.020	

Bursting pressure = 84 lbs. per square inch.

Experiment 11.

Globe n. Diameters 4·0 and 4·03 inches.

In parts of an inch.

Thicknesses measured	}	0·016	} Minimum = 0·016 inch.
		0·019	
		0·018	
		0·017	
		0·019	
		0·016	
		0·016	

Bursting pressure = 82 lbs. per square inch.

Crown-glass.

Experiment 12.

Globe p. Diameters 4·2 and 4·35 inches.

In parts of an inch.

Thicknesses measured	}	0·0252	} Minimum = 0·025 inch.
		0·0270	
		0·0272	
		0·030	
		0·0252	
		0·0252	
		0·0256	

Burst with 120 lbs. per square inch.

Experiment 13.

Globe q. Diameters 4·05 and 4·20 inches.

In parts of an inch.

Thicknesses measured	}	0·028	} Minimum = 0·021 inch.
		0·0236	
		0·0256	
		0·0236	
		0·0212	
		0·0212	
		0·0210	

Bursting pressure = 126 lbs. per square inch.

Experiment 14.

Globe r. Diameters 5·9 and 5·8 inches.

In parts of an inch.

Thicknesses measured	}	0·0334	} Minimum = 0·016 inch.
		0·020	
		0·0244	
		0·017	
		0·0172	
		0·0172	
		0·016	

Burst with 69 lbs. per square inch.

Experiment 15.

Globe s. Diameters { horizontal = 6·0 inches.
vertical = 6·3 inches.

In parts of an inch.

Thicknesses measured { 0·024
0·020
0·0228
0·0204
0·0270
0·0262 } Minimum = 0·020 inch.

Bursting pressure = 86 lbs. per square inch.

Experiment 16.

Ellipsoid t. Diameters 4·1 and 7·0 inches.

In parts of an inch.

Thicknesses measured { 0·0180
0·0208
0·0220
0·0160
0·0184
0·0170
0·0220 } Minimum 0·016 inch.

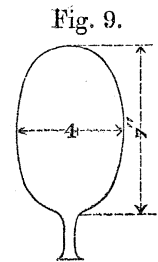

Bursting pressure = 80 lbs. per square inch.

Experiment 17.

Ellipsoid v. Diameters 4·0 and 7·0 inches.

In parts of an inch.

Thicknesses measured { 0·0206
0·0208
0·0224
0·0190
0·0206
0·022
0·021
0·0254 } Minimum = 0·019 inch.

Bursting pressure = 109 lbs. per square inch.

Summing up the preceding results, they are arranged in the following Table:—

Summary of Results.

TABLE V.—Resistance of Glass Globes to internal pressure.

Number of experiment.	Description of glass.	Diameter, in inches.	Thickness, in parts of an inch.	Bursting pressure, in pounds per square inch.
I.	} Flint-glass ...	4.0 × 3.98	0.024	84
II.		4.0 × 3.98	0.025	93
III.		4	0.038	150
IV.		4.5 × 4.55	0.056	280
V.		5.1 × 5.12	0.058	184
VI.		6	0.059	152
VIII.	} Green glass ...	4.95 × 5.0	0.022	90
IX.		4.95 × 5.0	0.020	85
X.		4.0 × 4.05	0.018	84
XI.		4.0 × 4.03	0.016	82
XII.	} Crown-glass...	4.2 × 4.35	0.025	120
XIII.		4.05 × 4.2	0.021	126
XIV.		5.9 × 5.8	0.016	69
XV.		6.0 × 6.3	0.020	86

TABLE VI.—Resistance of Glass Cylinders and Ellipsoids to internal pressure.

Number of experiment.	Description of glass.	Form of vessel.	Diameter, in inches.	Thickness, in parts of an inch.	Bursting pressure, in pounds per square inch.
VII.	Flint-glass	Cylinder	4.05 × 7.0	0.079	282
XVI.	Crown-glass.....	Ellipsoid	4.1 × 7.0	0.016	80
XVII.	Crown-glass.....	Ellipsoid	4.1 × 7.0	0.019	109

SECTION IV.—ON THE RESISTANCE OF GLASS GLOBES AND CYLINDERS TO AN EXTERNAL PRESSURE.

The following experiments are in continuation of, and supplementary to the researches on the collapse of wrought-iron vessels already alluded to. In this aspect they are the most important in their bearings and the most novel of any in the present memoir.

The method of conducting them did not differ in any essential detail from that pursued in the researches upon wrought-iron tubes, described in a former paper. A number of globes of varying dimensions were procured, and hermetically sealed by means of the blowpipe. In this state they were fixed in the interior of the strong wrought-iron boiler B (fig. 10) (capable of sustaining a pressure of about 2500 lbs. per square inch), in the position shown at A. The boiler or vessel B communicated by means of the pipe *a*, with a hydraulic force-pump having a plunger of three-quarters of an inch diameter, so that a uniform pressure of about 1000 lbs. per square inch could easily be obtained. In order to register the pressure, gauges of the Schaeffer construction (C) were employed, as before, affording, within small limits of error, certain and accurate indications of the increase of pressure obtained by the pump. The collapse of

the glass vessel was made known by a loud report, and by the instant recession of the moveable finger of the gauge *i*; the maximum pressure obtained was marked by a second finger *k*, and also, to prevent error from any accidental cause, by the eye of the observer*.

Fig. 10.

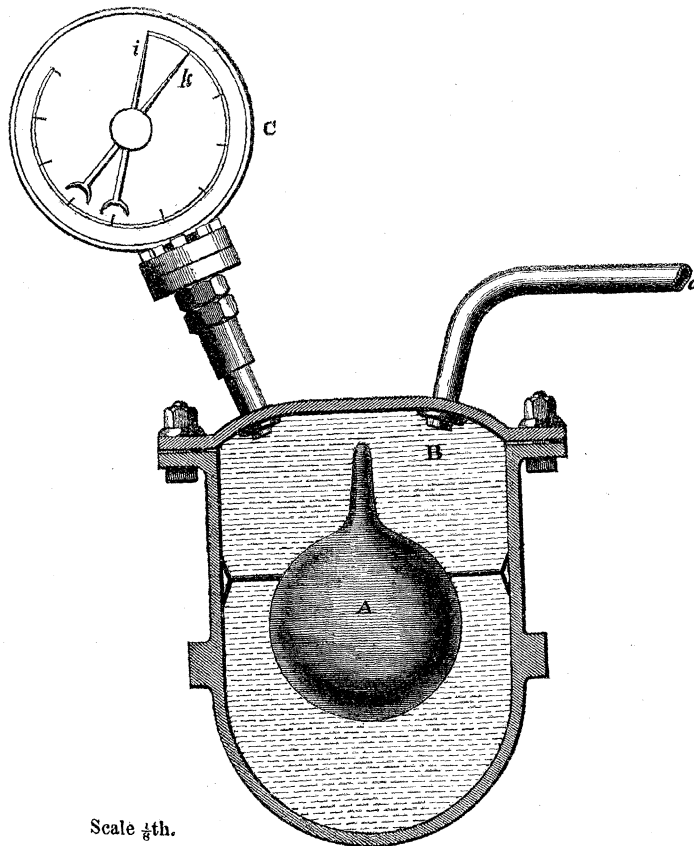

During the collapse the globes were reduced to the smallest fragments; in some cases a great part almost to powder, by the violence of the concussion. Hence in these experiments no indication could be found of the mode in which the globes had given way, nor of the direction of the primary lines of fracture.

After the globe had been ruptured, the fragments were carefully collected, and a selection having been made of the thinnest, they were measured, as before, by means of a micrometer-screw. The minimum thickness thus determined has been assumed for the thickness of the point of rupture in the calculations.

* In pressure-gauges of the Schaeffer construction a corrugated steel plate measures the force, by expanding under pressure. The indications are communicated by a rack and pinion to the hand of the gauge which moves over a face plate graduated by trial. In principle this gauge does not materially differ from the aneroid barometer.

Flint-glass.

Experiment 1.

Globe A. Diameters 5.05 and 4.76 inches.

In parts of an inch.

Thicknesses measured	0.0170	} Minimum = 0.014 inch.
	0.0192	
	0.0190	
	0.0218	
	0.0220	
	0.0146	
	0.0178	
	0.0154	

Collapsing pressure = 292 lbs. per square inch.

Experiment 2.

Globe B. Diameters 5.08 and 4.7 inches.

In parts of an inch.

Thicknesses measured	0.0210	} Minimum = 0.018 inch.
	0.0200	
	0.0180	
	0.0200	
	0.0194	
	0.0188	
	0.0192	
	0.0196	

Collapsing pressure = 410 lbs. per square inch.

Experiment 3.

Globe C. Diameters 4.95 and 4.72 inches.

In parts of an inch.

Thicknesses measured	0.0214	} Minimum = 0.022 inch.
	0.0246	
	0.0208	
	0.0220	
	0.0266	
	0.0222	
	0.0226	

Collapsing pressure = 470 lbs. per square inch.

Experiment 4.

Globe D. Diameter 5·6 inches.

Minimum thickness = 0·020 inch.

Collapsing pressure = 475 lbs. per square inch.

Experiment 5.

Globe E. Diameters 8·22 and 7·45 inches.

In parts of an inch.

Thicknesses measured	0·0152	} Minimum = 0·010 inch.
	0·0118	
	0·0122	
	0·0100	
	0·0106	
	0·0128	
	0·0108	
	0·0108	
	0·0110	
	0·0102	

Collapsing pressure = 35 lbs. per square inch.

Experiment 6.

Globe F. Diameters 8·2 and 7·2 inches.

In parts of an inch.

Thicknesses measured	0·0124	} Minimum = 0·012 inch.
	0·0138	
	0·0126	
	0·0116	
	0·0120	
	0·0120	

Collapsing pressure = 42 lbs. per square inch.

Experiment 7.

Globe G. Diameters 8·2 and 7·4 inches.

In parts of an inch.

Thicknesses measured	0·0160	} Minimum = 0·015 inch.
	0·0144	
	0·0166	
	0·0148	
	0·0144	
	0·0158	
	0·0164	
	0·0150	

Collapsing pressure = 60 lbs. per square inch.

Experiment 8.

Globe H. Diameters 4.0 and 3.98 inches.
 Minimum thickness = 0.024 inch.

This globe sustained unbroken a pressure of 900 lbs. per square inch.

Experiment 9.

Globe I. Diameter 4.0 inches.
 Minimum thickness = 0.025 inch.

This globe sustained unbroken a pressure of 900 lbs. per square inch.

Experiment 10.

Globe K. Diameter 6.0 inches.
 Minimum thickness = 0.059 inch.

This globe remained unbroken with a pressure of 1000 lbs. per square inch.

Experiment 11.

Cylinder L. Diameter 3.09 inches.
 Length 14 inches.

In parts of an inch.

Thicknesses measured $\left\{ \begin{array}{l} 0.0243 \\ 0.0241 \\ 0.0235 \\ 0.0238 \\ 0.0241 \\ 0.0352 \end{array} \right\}$ Minimum = 0.024 inch.

Collapsing pressure = 85 lbs. per square inch.

Fig. 11.

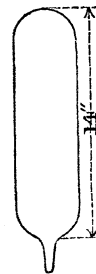

Experiment 12.

Cylinder M. Diameter 3.08 inches.
 Length 14 inches.

In parts of an inch.

Thicknesses measured $\left\{ \begin{array}{l} 0.0320 \\ 0.0324 \\ 0.052 \\ 0.0316 \\ 0.0326 \\ 0.0322 \end{array} \right\}$ Minimum = 0.032 inch.

Collapsing pressure = 103 lbs. per square inch.

Fig. 12.

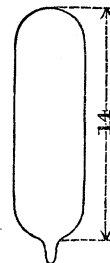

Experiment 13.

Cylinder N. Diameter 3.25 inches.

Length 14 inches.

In parts of an inch.

Thicknesses measured	}	0.0452	} Minimum = 0.042 inch.
		0.0436	
		0.0472	
		0.0422	
		0.0426	
		0.0436	
		0.0452	

Collapsing pressure = 175 lbs. per square inch.

Fig. 13.



Experiment 14.

Cylinder O. Diameter 4.05 inches.

Length 7.0 inches.

In parts of an inch.

Thicknesses measured	}	0.0454	} Minimum = 0.034 inch.
		0.0384	
		0.0368	
		0.0344	
		0.0348	
		0.0392	
		0.0348	

Collapsing pressure = 202 lbs. per square inch.

Fig. 14.

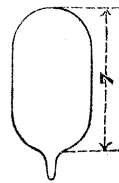

Experiment 15.

Cylinder P. Diameter 4.05 inches.

Length 7 inches.

In parts of an inch.

Thicknesses measured	}	0.0502	} Minimum = 0.046 inch.
		0.0464	
		0.0460	
		0.0464	
		0.0510	
		0.0498	
		0.0558	

Collapsing pressure = 380 lbs. per square inch.

Fig. 15.



Experiment 16.

Cylinder Q. Diameter 4.06 inches.
Length 13.8 inches.

In parts of an inch.

Thicknesses measured	}	0.0448	} Minimum = 0.043 inch.
		0.050	
		0.0474	
		0.0490	
		0.0476	
		0.0470	
		0.053	
		0.0434	

Fig. 16.



Collapsing pressure = 180 lbs. per square inch.

Experiment 17.

Cylinder R. Diameter 4.02 inches.
Length 13.8 inches.

In parts of an inch.

Thicknesses measured	}	0.0678	} Minimum = 0.064 inch.
		0.0664	
		0.0728	
		0.0718	
		0.0660	
		0.0644	
		0.0706	
		0.0682	

Fig. 17.



Collapsing pressure = 297 lbs. per square inch.

Experiment 18.

Cylinder S. Diameter 3.98 inches.
Length 14.0 inches.

In parts of an inch.

Thicknesses measured	}	0.0792	} Minimum = 0.076 inch.
		0.0774	
		0.0762	
		0.0812	
		0.0828	
		0.0848	
		0.0836	
		0.0778	
		0.0766	

Fig. 18.



Collapsing pressure = 382 lbs. per square inch.

Experiment 19.

Cylinder T. Diameter 4·05 inches.
Length 7·0 inches.

In parts of an inch.

Thicknesses measured	}	0·079	} Minimum = 0·079 inch.
		0·081	
		0·090	
		0·086	
		0·086	
		0·079	
		0·086	
		0·086	

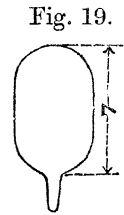

This cylinder remained unbroken after sustaining a pressure of 500 lbs. per square inch.

Experiment 20*.

Cylinder V. Diameter 4·2 inches.
Length 22 inches.

In parts of an inch.

Thicknesses measured	}	0·063	} Minimum = 0·055 inch.
		0·056	
		0·057	
		0·055	
		0·057	
		0·055	
		0·055	
		0·056	

Collapsed with 120 lbs. per square inch.

Experiment 21*.

Cylinder W. Diameter 4·1 inches.
Length 21·5 inches.

In parts of an inch.

Thicknesses measured	}	0·0535	} Minimum = 0·051 inch.
		0·051	
		0·055	
		0·052	
		0·053	
		0·060	
		0·057	
		0·0525	
		0·055	
		0·055	

Collapsed with 129 lbs. pressure per square inch.

* The experiments marked with an asterisk were not originally included in the calculations; but the results are strictly in conformity with those previously reduced.

Experiment 22*.

Cylinder X. Diameter 4.2 and 4.1 inches.

Length 22 inches.

In parts of an inch.

Thicknesses measured	0.0455	} Minimum = 0.0455 inch.
	0.047	
	0.047	
	0.049	
	0.047	
	0.047	
	0.052	
	0.047	
	0.049	
	0.047	
	0.054	
	0.046	

Collapsing pressure = 125 lbs. per square inch.

Green Glass.

Experiment 23.

Globe Z. Diameters 5.0 and 5.02 inches.

In parts of an inch.

Thicknesses measured	0.015	} Minimum = 0.0125 inch.
	0.013	
	0.0125	
	0.019	
	0.016	
	0.018	
	0.021	
	0.0126	
	0.013	

Collapsed with 212 lbs. per square inch.

TABLE VI.—Summary of the Results of Experiments upon the Resistance of Glass Globes to an External Pressure.

Number of experiments.	Description of glass.	Diameters, in inches.	Minimum thickness, in inches.	Collapsing pressure per square inch, in lbs.
I.	} Flint-glass ...	5·05 and 4·76	0·014	292
II.		5·08 and 4·7	0·018	410
III.		4·95 and 4·72	0·022	470
IV.		5·6	0·020	475
V.		8·22 and 7·45	0·010	35
VI.		8·2 and 7·2	0·012	42
VII.		8·2 and 7·4	0·015	60
VIII.		4·0 and 3·98	0·024	(900)*
IX.		4·0	0·025	(900)*
X.		6·0	0·059	(1000)*
XXIII.	Green glass	5·0 and 5·02	0·0125	212

TABLE VII.—Summary of Results of Experiments on the Resistance of Glass Cylinders to an External Force.

Number of experiment.	Description of glass.	Diameters, in inches.	Length, in inches.	Minimum thickness, in inches.	Collapsing pressure per square inch, in lbs.
XI.	} Flint-glass ...	3·09	14·0	0·024	85
XII.		3·08	14·0	0·032	103
XIII.		3·25	14·0	0·042	175
XIV.		4·05	7·0	0·034	202
XV.		4·05	7·0	0·046	380
XVI.		4·06	13·8	0·043	180
XVII.		4·02	13·8	0·064	297
XVIII.		3·98	14·0	0·076	382
XIX.		4·05	7·0	0·079	(500)†
XX.		4·20	22·0	0·055	120
XXI.		4·10	21·5	0·051	129
XXII.		4·15	22·0	0·046	125

* These globes remained unbroken.

† Remained unbroken.

SECTION V.—REDUCTION OF THE PRECEDING RESULTS.

I. *Generalization of the Results of Experiments on the Resistance of Glass Globes and Cylinders to External Pressure.*

Let us assume—

P = the external pressure in pounds per square inch to produce rupture.

D = the diameter of the globe or tube, as the case may be, in inches.

k = the thickness of the glass in inches.

p = the pressure P reduced to unity of thickness, viz. $k = \cdot 01$ inch.

C, α , β , constants to be determined from the data supplied by the experiments.

Then for the globes we assume

$$P = \frac{Ck^\alpha}{D^\beta}, \dots \dots \dots (1.)$$

and for the cylinders

$$P = \frac{C'k^\alpha}{D^{\beta'}L^{\alpha'}}, \dots \dots \dots (2.)$$

where the exponent of the thickness is the same in both formulæ.

Hence we find for globes of the same diameter and also for cylinders of the same length and diameter,—

$$\alpha = \frac{\log P_1 - \log P_2}{\log k_1 - \log k_2} \dots \dots \dots (3.)$$

Taking the results of Experiments I. and II., we find $\alpha = 1.35$; from V. and VII. we find $\alpha = 1.33$; from XI. and XII. we find $\alpha = 1.28$; from XVI. and XVII. we find $\alpha = 1.26$; and from XV. and XIV. we find $\alpha = 2$. Hence we get for the mean value of α ,

$$\alpha = \frac{1}{5}\{1.35 + 1.33 + 1.28 + 1.26 + 2\} = 1.4.$$

Again, the following formula enables us to reduce the pressure P, of the cylinders as well as of the globes, to unity of thickness,

$$\log p = \log P - \alpha \log (100 k) \dots \dots \dots (4.)$$

Making these calculations, we obtain the following Tables of results:—

TABLE VIII.—Reduction of the Results of Experiments on the Resistance of Glass Globes to unity of thickness.

Number of experiment.	D. Diameter, in inches.	k. Thickness, in inches.	P. Collapsing pressure, in lbs. per square inch.	p. P reduced to unity of thickness.
I.	5.05	.014	292	178
II.	5.08	.018	410	168
III.	4.95	.022	470	156
IV.	5.60	.020	475	180
V.	8.22	.010	35	35
VI.	8.20	.012	42	32.54
VII.	8.20	.015	60	34.01

TABLE IX.—Reduction of the Results of Experiments on the Resistance of Glass Cylinders to unity of thickness.

Number of experiment.	D. Diameter, in inches.	L. Length, in inches.	k. Thickness, in inches.	P. Collapsing pressure, in lbs. per square inch.	$\frac{p}{P}$ reduced to unity of thickness.
XI.	3.09	14	0.024	85	27.36
XII.	3.08	14	0.032	103	20.23
XIII.	3.25	14	0.042	175	23.47
XIV.	4.05	7	0.034	202	36.41
XV.	4.05	7	0.046	380	44.86
XVI.	4.06	13.8	0.043	180	23.36
XVII.	4.02	13.8	0.064	297	22.10
XVIII.	3.98	14	0.076	382	22.33

Let D_1, p_1 be put for the data derived from Experiment 1; D_2, p_2 for the data derived from Experiment 2, and so on; then we get from equation (1.),

$$\beta = \frac{\log p_1 + \log p_2 + \log p_3 - (\log p_5 + \log p_6 + \log p_7)}{\log D_5 + \log D_6 + \log D_7 - (\log D_1 + \log D_2 + \log D_3)} \dots \dots \dots (5.)$$

$$\beta = \frac{\log p_1 - \log p_7}{\log D_7 - \log D_1} \dots \dots \dots (6.)$$

$$\beta = \frac{\log p_2 + \log p_3 + \log p_4 - (\log p_5 + \log p_6 + \log p_7)}{\log D_5 + \log D_6 + \log D_7 - (\log D_2 + \log D_3 + \log D_4)} \dots \dots \dots (7.)$$

From equation (5.) we find $\beta = 3.43$; from equation (6.) we find $\beta = 3.25$; and from equation (7.) we find $\beta = 3.56$; and the mean of these values gives

$$\beta = \frac{1}{3}(3.43 + 3.25 + 3.56) = 3.4.$$

For the value of the constant C, we find

$$\log C = \frac{1}{7}(\log p_1 + \dots + \log p_7) + \frac{\beta}{7}(\log D_1 + \dots + \log D_7) + 2\alpha, \dots \dots (8.)$$

whence we find $C = 28,300,000$.

Substituting the values of α, β, C thus obtained in the general formula (1.), we get

$$P = 28,300,000 \times \frac{k^{1.4}}{D^{3.4}} \dots \dots \dots (9.)$$

which is the general formula for calculating the strength of flint-glass globes subjected to external pressure. In order to facilitate calculation, this formula may be written

$$\log P = 4.6518 + 1.4 \log(100 k) - 3.4 \log D. \dots \dots \dots (10.)$$

Calculating the value of P by this formula from the data of Experiment XXIII., viz. $D = 5$ and $k = .0125$, we find

$$\log P = 4.6518 + 1.4 \log 1.25 - 3.4 \log 5 = \log 258,$$

that is $P = 258$ lbs. Now this would be the crushing pressure supposing the globe to be flint-glass; but the crushing pressure given by the experiment is 212 lbs.; hence it appears that the resistance of green glass to external pressure differs very little from that of flint-glass. The following Table will show how nearly formula (9.) represents the results of the experiments on glass globes.

TABLE X.—Results of Experiments on the Resistance of Glass Globes to External Pressure.

Number of experiment.	D.	k.	P by experiment.	P by formula (9).	Proportional error by formula.
I.	5.05	.014	292	292	0
II.	5.08	.018	410	408	$-\frac{1}{100}$
III.	4.95	.022	470	580	$+\frac{1}{4}$
IV.	5.6	.020	475	340	$-\frac{1}{4}$
V.	8.22	.010	35	35	0
VI.	8.2	.012	42	44.8	$+\frac{1}{20}$
VII.	8.2	.015	60	61.3	$+\frac{1}{50}$
VIII.	4.0	.024	900*	1370	...
IX.	4.0	.025	900*	1450	...
X.	6.0	.059	1000*	1218	...
XXIII.	5.02	.0125	212†	258	$+\frac{1}{5}$

The lengths of the cylinders of Experiments XI., XII., and XIII. are the same, and their diameters are nearly equal to one another. The same observation applies to the cylinders of Experiments XIV. and XV., and also to Experiments XVI. and XVII. In order, therefore, to reduce the pressures p to uniformity of diameter, we may assume, for such small differences, that D varies as $\frac{1}{P}$. These reductions being made, we may obtain the following Table:—

TABLE XI.—Reduction of the Results of Experiments on Glass Cylinders to uniformity of Diameter, &c.

Number of experiment.	D. Diameter, in inches.	L. Length, in inches.	$\frac{p}{k}$ P reduced to unity of thickness.	$p D L$.
11, 12, 13.	3	14	24.81	1042
14, 15.	4.05	7	40.63	1151
16, 17.	4.05	13.8	22.67	1260
18.	3.98	14	22.33	1240

$$\text{Mean value of } p D L = \frac{4)4693}{1173}$$

Here the continued product of the pressure, diameter, and length is shown to be very nearly a constant quantity, the thickness of the glass being the same, that is for $k = .01$. Hence we have

$$C = \frac{p D L}{.01^2} \dots \dots \dots (11.)$$

Now the mean value of $p D L$ is 1173, as shown in Table XI., and $\alpha = 1.4$, as deter-

* Remained unbroken.

† Green glass.

mined by equation (3.); hence we find

$$C = \frac{1173}{.01^{1.4}} = 740,000.$$

Substituting these values of the constants in equation (2.), we get

$$P = 740,000 \frac{k^{1.4}}{DL}, \dots \dots \dots (12.)$$

which is the general formula for calculating the strength of glass cylinders subjected to external pressure, within the limits indicated by the experiments, that is, provided their length is not less than twice their diameter, and not greater probably than six times their diameter. This law of strength is precisely similar to that found for sheet-iron tubes.

For convenience of calculation, this formula may be written

$$\log P = 3.06923 + 1.4 \log (100 k) - \log (DL) \dots \dots \dots (13.)$$

The following Table will show how nearly formula (12.) represents the results of the experiments on glass cylinders:—

TABLE XII.—Results of Experiments on the Resistance of Glass Cylinders to External Pressure.

Number of experiment.	D.	L.	k.	P by experiment.	P by formula.	Proportional error by formula.
XI.	3.09	14	.024	85	86	+ $\frac{1}{80}$
XII.	3.08	14	.032	103	138	+ $\frac{1}{3}$
XIII.	3.25	14	.042	175	192	+ $\frac{1}{9}$
XIV.	4.05	7	.034	202	227	+ $\frac{1}{10}$
XV.	4.05	7	.046	380	351	- $\frac{1}{13}$
XVI.	4.06	13.8	.043	180	161	- $\frac{1}{9}$
XVII.	4.02	13.8	.064	297	284	- $\frac{1}{20}$
XVIII.	3.98	14	.076	382	361	- $\frac{1}{8}$
XIX.	4.05	7	.079	500	747	Unbroken.
XX.	4.2	22	.055	120	138	+ $\frac{1}{7}$
XXI.	4.1	21.5	.051	129	130	+ $\frac{1}{129}$
XXII.	4.2	22	.0455	125	107	- $\frac{1}{7}$

Comparative Strength of Glass and Sheet-iron Cylinders subjected to an External Pressure tending to produce Collapse.

The formula of strength for sheet-iron cylinders, after reducing L to inches, is

$$P' = 806,300 \times 12 \times \frac{k^{2.19}}{LD}$$

Now for cylinders of the same diameter, length, and thickness, we find, by dividing equation (12.) by the above,

$$\frac{P}{P'} = \frac{.0764}{k^{.79}} \dots \dots \dots (14.)$$

When $k = .043$, as in most of the experiments on iron, then $\frac{P}{P'} = \frac{11}{12}$; that is, in this case, the strengths of the two cylinders will be nearly equal to one another.

II. *Generalization of the Results of the Experiments on the Resistance of Glass Globes, Cylinders, and Ellipsoids to Internal Pressure.*

Let D = the diameter of the globe or cylinder, as the case may be.

k = the thickness of the material in inches.

a = the longitudinal sectional area of the material in square inches; that is, in the direction of the line of rupture, or line of minimum strength.

A = the longitudinal section in square inches.

P = the bursting pressure in lbs. per square inch.

T = the tenacity of the material in lbs. per square inch.

Then we find

$$P = \frac{aT}{A}; \dots \dots \dots (15.)$$

$$\therefore T = \frac{PA}{a}; \dots \dots \dots (16.)$$

that is, $\frac{PA}{a}$ is a constant for vessels of the same material. This theoretical deduction is fully confirmed by the results of these experiments, as arranged in the following Table:—

TABLE XIII.—Resistance of Glass Globes, Cylinders, and Ellipsoids to an Internal Pressure.

No. of exper.	Description of glass.	D.	k .	P.	Value of $\frac{PA}{a}$.	Mean value of $\frac{PA}{a}$.
1.	Flint-glass	4 and 3.98	.024	84	3500	4200
2.		4 and 3.98	.025	93	3710	
3.		4	.038	150	3950	
4.		4.5 and 4.55	.056	280	5650	
5.		5.1 and 5.12	.058	184	4050	
6.		6	.059	152	3870	
7.		4.05 and 7	.079	282	4660	
8.	Green glass	4.95 and 5	.022	90	4040	4800
9.		4.95 and 5	.020	85	5280	
10.		4 and 4.05	.018	84	4690	
11.		4 and 4.03	.016	82	5150	
12.	Crown-glass	4.2 and 4.35	.025	120	5120	6000
13.		4.2 and 4.05	.021	126	6190	
14.		5.9 and 5.8	.016	69	6300	
15.		6 and 6.3	.020	86	5290	
16.		4.1 and 7	.016	80	6360	
17.		4 and 7	.019	109	6900	

Hence we have the tenacity of glass,—

$$\begin{array}{l} \text{lbs. per sq. in.} \\ T=4200, \text{ for flint-glass,} \end{array}$$

$$T=4800, \text{ for green glass,}$$

and

$$T=6000, \text{ for crown-glass.}$$

The general equation (15.) then becomes—

$$\begin{array}{l} \text{lbs. per sq. in.} \\ P=4200 \times \frac{a}{A}, \text{ for flint-glass,} \end{array}$$

$$P=4800 \times \frac{a}{A}, \text{ for green glass,}$$

$$P=6000 \times \frac{a}{A}, \text{ for crown-glass.}$$

For globes of uniform diameter and thickness these formulæ become—

$$\begin{array}{l} \text{lbs. per sq. in.} \\ P=16,800 \times \frac{k}{D}, \text{ for flint-glass,} \end{array}$$

$$P=19,200 \times \frac{k}{D}, \text{ for green glass,}$$

$$P=24,000 \times \frac{k}{D}, \text{ for crown-glass.}$$

III. *Generalization of the Results of Experiments on the Tensile and Compressive Resistances of Glass.*

Mean tenacity (T_1) of glass in the form of bars

$$= \frac{1}{4}(2286 + 2540 + 2890 + 2540) = 2560 \text{ lbs. per square inch ;}$$

Mean tenacity (T'_1) of glass in the form of thin plates

$$= \frac{1}{3}(4200 + 4800 + 6000) = 5000 \text{ lbs. per square inch ;}$$

$$\therefore \frac{T'_1}{T_1} = \frac{5000}{2560} = 2 \text{ nearly,}$$

that is, the tenacity of glass in the form of thin plates is about twice that of glass in the form of bars.

Mean resistance (T_2) of glass to compression

$$= \frac{1}{3}(27582 + 31876 + 31003) = 30,150 \text{ lbs. per square inch ;}$$

$$\therefore \frac{T_2}{T_1} = \frac{30150}{2560} = 11.8 \text{ nearly,}$$

that is, the ultimate resistance of glass to a crushing force is about twelve times its resistance to extension.

IV. *Resistance of Rectangular Glass Bars to a Transverse Strain.*

Let l = the length of the bar supported at the ends and loaded in the middle.

W = breaking weight in lbs.

K = area of the whole transverse section.

D = the whole depth of the section.

d, d_1 = the respective distances of the top and bottom edges from the neutral axis.

T_1 = the tensile resistance of the material in lbs. per square inch.

T_2 = the compressive resistance of the material in lbs. per square inch.

Then we have "TATE'S strength of material" equations (27.) and (6.)—

$$W = \frac{4}{3} \cdot \frac{T_1 d_1 K}{l}, \text{ and } \frac{T_1}{T_2} = \frac{d}{d_1};$$

hence we get

$$W = \frac{4}{3} \cdot \frac{T_1 \cdot T_2}{T_1 + T_2} \times \frac{K \cdot D}{l} = C \frac{K \cdot D}{l}, \dots \dots \dots (17.)$$

where the constant

$$C = \frac{4}{3} \cdot \frac{T_1 \cdot T_2}{T_1 + T_2} = \frac{4}{3} \times \frac{2560 \times 30150}{32710} = 3140 \text{ nearly.}$$

Substituting this value of the constant, equation (16.) becomes

$$W = 3140 \cdot \frac{K \cdot D}{l}, \dots \dots \dots (18.)$$

which expresses the transverse strength of a rectangular bar of glass supported at the ends and loaded in the middle.